

VACON[®] 20
VACON[®] 20 X
VACON[®] 20 CP
AC DRIVES

MODBUS RTU
USER MANUAL

VACON[®]

TABLE OF CONTENTS

Document: DPD01925A
Version release date: 30.5.17

1. Safety	2
1.1 Danger.....	2
1.2 Warnings.....	3
1.3 Earthing and earth fault protection.....	4
2. Modbus - general info	5
2.1 Restrictions.....	6
3. Modbus technical data	7
3.1 Modbus RTU protocol.....	7
3.2 Connections and wiring.....	7
4. Installation	8
4.1 Installation in VACON® 20 family AC drives.....	8
4.1.1 Preparation for use through RS485.....	8
5. Fieldbus parametrization	10
5.1 Fieldbus control and basic reference selection.....	10
5.2 Modbus RTU parameters and monitoring values.....	10
5.2.1 Fieldbus protocol.....	11
5.2.2 Slave address.....	11
5.2.3 Baud rate.....	11
5.2.4 Parity type.....	12
5.2.5 Communication timeout.....	12
5.2.6 Reset communication status.....	12
5.2.7 Communication status.....	12
6. Communications	13
6.1 Modbus address area.....	13
6.2 Supported Modbus Functions.....	13
6.3 Modbus data mapping.....	14
6.3.1 Modbus process data in VACON® 20 Application ACCN1004.....	14
6.3.2 Modbus process data in VACON® 20X and VACON® CP Application ACIT1075.....	17
6.4 Example messages.....	20
6.4.1 Example 1 - Write Process Data.....	20
6.4.2 Example 2 - Read process data.....	21
7. Fault tracing	22
7.1 Typical fault conditions.....	22
7.2 RS-485 bus biasing.....	22
7.3 Other fault conditions.....	23
8. Quick setup	24
9. APPENDIX 1 - PROCESS DATA	25



1. SAFETY

This manual contains clearly marked cautions and warnings which are intended for your personal safety and to avoid any unintentional damage to the product or connected appliances.

Please read the information included in cautions and warnings carefully.

The cautions and warnings are marked as follows:

Table 1. Warning signs

	= DANGER! Dangerous voltage
	= WARNING or CAUTION
	= Caution! Hot surface

1.1 DANGER



The **components of the power unit are live** when the drive is connected to mains potential. Coming into contact with this voltage is **extremely dangerous** and may cause death or severe injury.



The **motor terminals U, V, W and the brake resistor terminals are live** when the AC drive is connected to mains, even if the motor is not running.



After disconnecting the AC drive from the mains, **wait** until the indicators on the keypad go out (if no keypad is attached see the indicators on the cover). Wait 5 more minutes before doing any work on the connections of the drive. Do not open the cover before this time has expired. After expiration of this time, use a measuring equipment to absolutely ensure that no voltage is present. **Always ensure absence of voltage before starting any electrical work!**



The control I/O-terminals are isolated from the mains potential. However, the **relay outputs and other I/O-terminals may have a dangerous control voltage** present even when the AC drive is disconnected from mains.



Before connecting the AC drive to mains make sure that the front and cable covers of the drive are closed.



During a ramp stop (see the Application Manual), the motor is still generating voltage to the drive. Therefore, do not touch the components of the AC drive before the motor has completely stopped. Wait until the indicators on the keypad go out (if no keypad is attached see the indicators on the cover). Wait additional 5 minutes before starting any work on the drive.

1.2 WARNINGS



The AC drive is meant for **fixed installations only**.



Do not perform any measurements when the AC drive is connected to the mains.



The **earth leakage current** of the AC drives exceeds 3.5mA AC. According to standard EN61800-5-1, a **reinforced protective ground connection** must be ensured. See chapter 1.3.



If the AC drive is used as a part of a machine, the **machine manufacturer is responsible** for providing the machine with a **supply disconnecting device** (EN 60204-1).



Only **spare parts** delivered by VACON® can be used.



At power-up, power break or fault reset **the motor will start immediately** if the start signal is active, unless the pulse control for Start/Stop logic has been selected. Furthermore, the I/O functionalities (including start inputs) may change if parameters, applications or software are changed. Disconnect, therefore, the motor if an unexpected start can cause danger.



The **motor starts automatically** after automatic fault reset if the auto restart function is activated. See the Application Manual for more detailed information.



Prior to measurements on the motor or the motor cable, disconnect the motor cable from the AC drive.



Do not touch the components on the circuit boards. Static voltage discharge may damage the components.



Check that the **EMC level** of the AC drive corresponds to the requirements of your supply network.

1.3 EARTHING AND EARTH FAULT PROTECTION



CAUTION!

The AC drive must always be earthed with an earthing conductor connected to the earthing terminal marked with .

The earth leakage current of the drive exceeds 3.5mA AC. According to EN61800-5-1, one or more of the following conditions for the associated protective circuit shall be satisfied:

- b) The protective conductor shall have a cross-sectional area of at least 10 mm² Cu or 16 mm² Al, through its total run.
- c) Where the protective conductor has a cross-sectional area of less than 10 mm² Cu or 16 mm² Al, a second protective conductor of at least the same cross-sectional area shall be provided up to a point where the protective conductor has a cross-sectional area not less than 10 mm² Cu or 16 mm² Al.
- d) Automatic disconnection of the supply in case of loss of continuity of the protective conductor.

The cross-sectional area of every protective earthing conductor which does not form part of the supply cable or cable enclosure shall, in any case, be not less than:

- 2.5mm² if mechanical protection is provided or
- 4mm² if mechanical protection is not provided.

The earth fault protection inside the AC drive protects only the drive itself against earth faults in the motor or the motor cable. It is not intended for personal safety.

Due to the high capacitive currents present in the AC drive, fault current protective switches may not function properly.



Do not perform any voltage withstand tests on any part of the AC drive. There is a certain procedure according to which the tests shall be performed. Ignoring this procedure may result in damaged product.

NOTE! You can download the English and French product manuals with applicable safety, warning and caution information from

<http://drives.danfoss.com/knowledge-center/technical-documentation/>.

REMARQUE Vous pouvez télécharger les versions anglaise et française des manuels produit contenant l'ensemble des informations de sécurité, avertissements et mises en garde

applicables sur le site <http://drives.danfoss.com/knowledge-center/technical-documentation/>

.

2. MODBUS - GENERAL INFO

Modbus is a communication protocol developed by Modicon systems. In simple terms, it is a way of sending information between electronic devices. The device requesting the information is called the Modbus Master and the devices supplying information are Modbus Slaves. The Master can also write information to the Slaves. Modbus is typically used to transmit signals from instrumentation and control devices back to a main controller or data gathering system.

Standard Modbus network contains one Master device and up to 247 Slave devices. In ModbusRTU networks it is mandatory to define a unique Slave Address (or Unit identifier number) for the every Slave Device. Slave Address is a number between 1 and 247. Modbus ASCII mode is not supported.

The Modbus communication interface is built around messages. The format of these Modbus messages is independent of the type of physical interface used. The same protocol can be used regardless of the connection type. Because of this, Modbus gives the possibility to easily upgrade the hardware structure of an industrial network, without the need for large changes in the software. A device can also communicate with several Modbus nodes at once, even if they are connected with different interface types, without the need to use a different protocol for every connection.

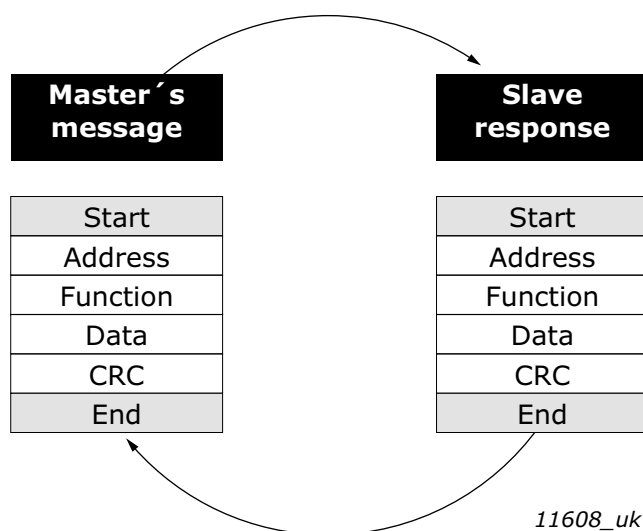

Figure 1. Basic structure of Modbus frame

On simple interfaces like RS485, the Modbus messages are sent in plain form over the network. In this case the network is dedicated to Modbus.

Each Modbus message has the same structure. Four basic elements are present in each message. The sequence of these elements is the same for all messages, to make it easy to parse the content of the Modbus message. A conversation is always started by a master in the Modbus network. A Modbus master sends a message and—depending of the contents of the message—a slave takes action and responds to it. Addressing in the message header is used to define which device should respond to a message. All other nodes on the Modbus network ignore the message if the address field does not match their own address.

Your VACON® 20 family AC drive is equipped with Modbus support as standard. If you need to contact VACON® service in problems related to Modbus, send a description of the problem together with the Drive Info File taken with VACON® Live to customer support. If possible, also send a "Wire-shark" log from the situation if applicable.

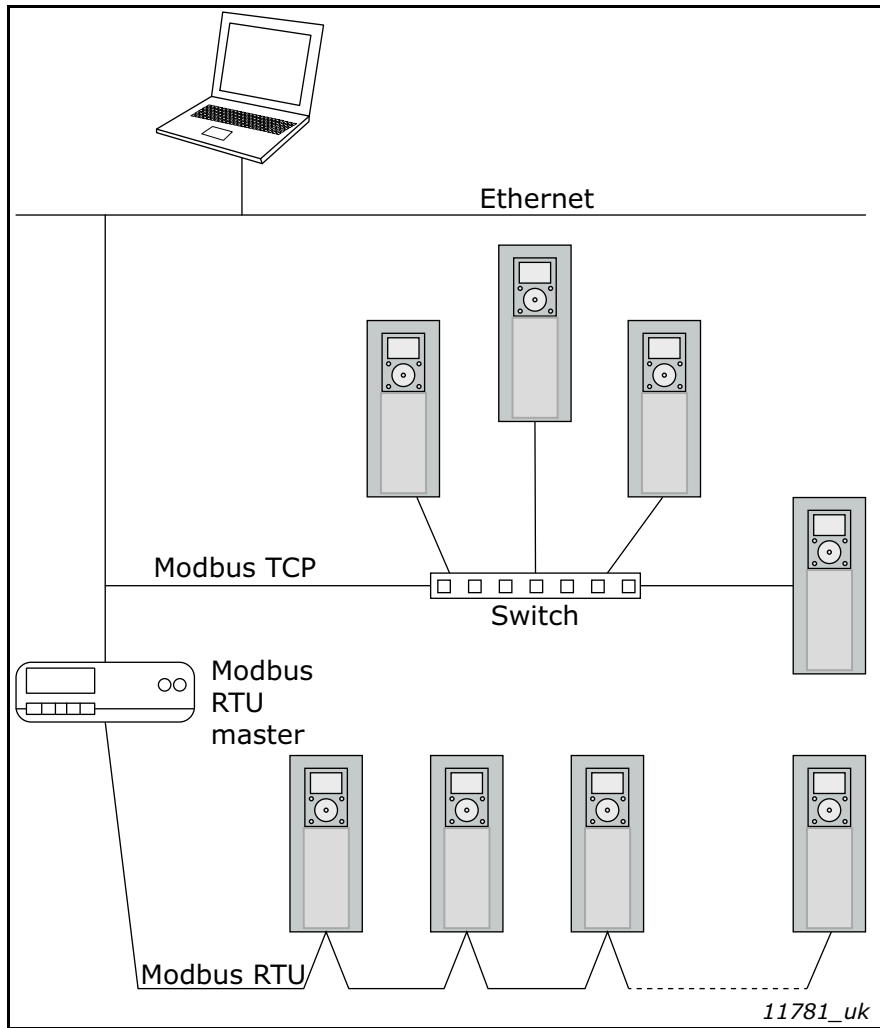

Figure 2. Principal example diagram of Modbus

2.1 RESTRICTIONS

When a fieldbus option board or an OPTBH option board has been installed, Modbus is not working.

3. MODBUS TECHNICAL DATA

3.1 MODBUS RTU PROTOCOL

Modbus RTU is the only supported transmission mode. Modbus ASCII mode is not supported.

Table 2.

Connections and communications	Interface	RS-485
	Data transfer method	RS-485 MS/TP, half-duplex
	Transfer cable	STP (Shielded Twisted Pair)
	Connector	2.5 mm ²
	Electrical isolation	Functional
	Modbus RTU	As described in "Modicon Modbus Protocol Reference Guide"
	Bitrate	300, 600, 1200, 2400, 4800, 9600, 19200, 38400, and 57600 bits/s
	Addresses	1 to 247

3.2 CONNECTIONS AND WIRING

The maximum length of an RS-485 cable depends on the bitrate used, the cable (gauge, capacitance or characteristic impedance) and the number of devices in the bus. The Modbus RTU specification states that for a maximum 9600 bits/second bitrate and AWG26 or wider gauge, the maximum length is 1000 meters. The actual cable length used in an installation can be lower than this number depending on the aforementioned parameters.

4. INSTALLATION

4.1 INSTALLATION IN VACON® 20 FAMILY AC DRIVES

The connection for RS485 is on the standard I/O terminals (A and B). See VACON® 20 or VACON® 20 X /CP Installation Manual depending on the drive you are using.

4.1.1 PREPARATION FOR USE THROUGH RS485

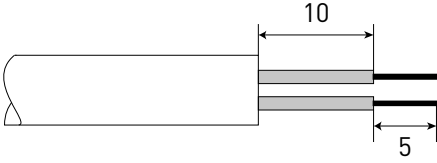
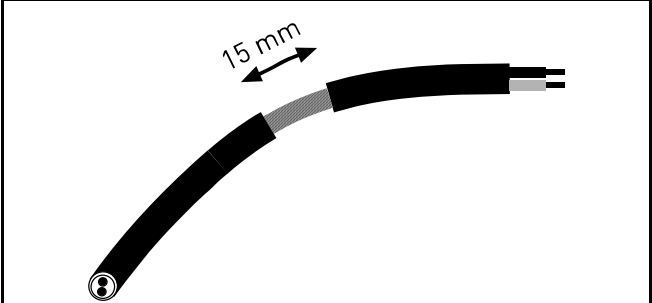
<h1>1</h1>	<p>Strip about 15 mm of the RS485 cable and cut off the grey cable shield. Remember to do this for both bus cables (except for the last device). Leave no more than 10 mm of the cable outside the terminal block and strip the cables at about 5 mm to fit in the terminals. See picture below.</p> <div style="text-align: center;">  </div> <p>Also strip the cable now at such a distance from the terminal that you can fix it to the frame with the grounding clamp. Strip the cable at a maximum length of 15 mm. Do not strip the aluminium cable shield!</p> <div style="text-align: center;">  </div>
<h1>2</h1>	<p>Then connect the cable to its appropriate terminals on VACON® 20 CP AC drive standard terminal block, terminals A and B (A = negative, B = positive).</p>
<h1>3</h1>	<p>Using the cable clamp included in the supply of the drive, ground the shield of the RS485 cable to the frame of the AC drive.</p>

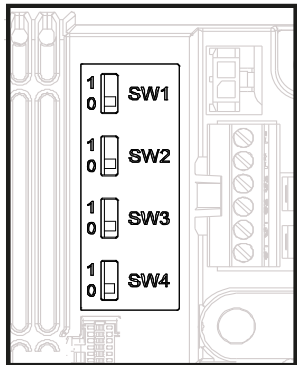
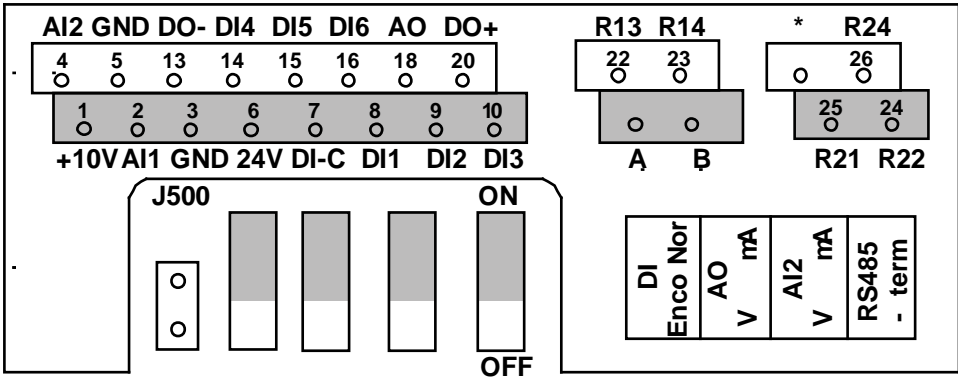
4	<p>NOTE! This step is valid only for VACON® 20 CP and VACON® 20 X.</p> <p>If VACON® 20 Cold Plate drive is the last device on the bus, the bus termination must be set. Locate the switches to the right of the control terminals and turn the SW4 switch to position "0". Biasing is built in the termination resistor.</p> 
5	<p>NOTE! This step is valid only for VACON® 20.</p> <p>The RS-485 bus is terminated with termination resistors of 120 ohms in both ends. VACON® 20 has a built-in termination resistor which is switched off as a default (presented below). The termination resistor can be switched on and off with the right hand dip switch located above IO-terminals in the front of the drive (see below). Biasing is built in the termination resistor.</p> 
6	<p>NOTE: When planning the cable runs, remember to keep the distance between the fieldbus cable and the motor cable at a minimum of 30 cm.</p>
7	<p>The bus termination must be set for the first and the last device of the fieldbus line. We recommend that the first device terminated is the Master device.</p>

5. FIELDBUS PARAMETRIZATION

The following chapter describes briefly how to parametrise the AC drive in order for the motor to be controllable via fieldbus. These instructions are written for basic applications. For more information, consult the application-specific manual.

In order for the AC drive to accept commands from the fieldbus network, the control place of the AC drive has to be set to fieldbus. The default value of the parameter "Control Place" is usually I/O. Note that if the control unit firmware is updated, the default settings are restored. In addition, some applications may have the remote speed reference selection set by default to other than fieldbus. In these cases, the speed reference selection must be set to fieldbus, in order for the speed reference to be controlled via fieldbus.

NOTE! The motor control mode should be selected to support the used process and profile.

The navigation path to the fieldbus parameters may differ from application to application. The exemplary paths below apply to the VACON® 20 family AC drive.

5.1 FIELDBUS CONTROL AND BASIC REFERENCE SELECTION

The following tables list some of the parameters related to fieldbus control. See the application specific manuals for more detailed information.

Parameters can be read and written by using the drive panel, PC Tool or fieldbus protocol. Notice that some of connection parameters for fieldbus may need to be set (depending on your configuration) via panel or PC tool, before you can connect over fieldbus and write application parameters.

Table 3. Parametrization for VACON® 20 family AC drive (Standard application)

Parameter name	Value
Control mode	Frequency Speed
Remote control place	Fieldbus CTRL
Local / remote	Remote
Fieldbus ref. sel.	Fieldbus

5.2 MODBUS RTU PARAMETERS AND MONITORING VALUES

Table 4.

Code	Parameter	Min	Max	Unit	Default	ID	Description
When no fieldbus board or no OPTBH board has been installed, the following values are visible:							
V2.1	Communication status					808	Status of Modbus communication. Format: xx.yyy where xx = 0 - 64 (Number of error messages) This counter saturates when 64 error messages are detected yyy = 0 - 999 (Number of good messages) This counter restarts counting from 0 when 999 good messages are detected

Table 4.

Code	Parameter	Min	Max	Unit	Default	ID	Description
V2.9 *	Last communication fault					816	The fault code related to the last counted bad messages is shown: 1 = Illegal function 2 = Illegal address 3 = Illegal data value 4 = Illegal slave device 53 = USART receive fault (parity error/ frame error/USART buffer overflow) 90 = Receive buffer overflow 100 = Frame CRC Error 101 = Ring buffer overflow
P2.2	Fieldbus protocol	0	1		0	809	0 = Not used 1 = Modbus used
P2.3	Slave address	1	247		1	810	
P2.4	Baud rate	0	8		5	811	0 = 300 1 = 600 2 = 1200 3 = 2400 4 = 4800 5 = 9600 6 = 19200 7 = 38400 8 = 57800
P2.6	Parity type	0	2		0	813	Parity type: 0 = None 1 = Even 2 = Odd Stop bit: - 2-bits with parity type "None"; - 1-bit with parity type "Even" and "Odd".
P2.7	Communication time out	0	255	s	10	814	
P2.8	Reset communication status	0	1		0	815	

[*] Only on VACON® 20CP/X.

5.2.1 FIELD BUS PROTOCOL

Use this parameter to activate the Modbus protocol.

5.2.2 SLAVE ADDRESS

Each slave must have a unique address (from 1 to 247) so that it can be addressed independently from other nodes.

5.2.3 BAUD RATE

Select the communication speed for the network. The default value is 9600 baud.

5.2.4 PARITY TYPE

You can select the parity type for the network. Modbus RTU specifies the stop bit configuration shown in table below. You can modify this stop bit configuration manually using parameter.

Table 5. Parity type and stop bits

Parity	Stopbits
Even	1
Odd	1
None	2

5.2.5 COMMUNICATION TIMEOUT

Modbus initiates a communication error for a time defined with this parameter. '0' means that no fault is generated.

5.2.6 RESET COMMUNICATION STATUS

Used to reset the communication status shown in monitor value V2.1.

5.2.7 COMMUNICATION STATUS

The Communication status shows how many good and bad messages the drive has received. The Communication status includes a common error counter that counts CRC and parity errors and a counter for good messages.

Only messages to the current slave in use are counted in the good messages.

Table 6. Communication status description

Good messages	
0...999	Number of messages received without errors
Bad messages	
0...64	Number of messages received with errors

6. COMMUNICATIONS

Features of the Modbus-Vacon interface:

- Direct control of VACON[®] drive (e.g. Run, Stop, Direction, Speed reference, Fault reset)
- Full access to all VACON[®] parameters
- Monitor VACON[®] status (e.g. Output frequency, Output current, Fault code)

6.1 MODBUS ADDRESS AREA

The Modbus interface of VACON[®] 20/X uses the ID numbers of the application parameters as addresses. The ID numbers can be found in the parameter tables described in specific Application Manual.

When several parameters / monitoring values are read at a time, they must be consecutive.

11 addresses can be read and the addresses can be parameters or monitoring values.

NOTE: With some PLC manufacturers, the interface driver for Modbus RTU communication may contain an offset of 1 (the ID number to be used would then subtract 1).

6.2 SUPPORTED MODBUS FUNCTIONS

The VACON[®] variables and fault codes as well as the parameters can be read and written from Modbus. The parameter addresses are determined in the application. Every parameter and actual value have been given an ID number in the application. The ID numbering of the parameter as well as the parameter ranges and steps can be found in the application manual in question. The parameter value must be given without decimals. If several parameters/actual values are read with one message, the addresses of the parameters/actual values must be consecutive.

Table 7. Modbus RTU

Function (dec)	Function Name	Address	Broadcast messages
3	Read Holding Registers	All ID numbers	No
4	Read Input Registers	All ID numbers	No
6	Write Single Register	All ID numbers	Yes
16	Write Multiple Registers	All ID numbers	Yes

6.3 MODBUS DATA MAPPING

6.3.1 MODBUS PROCESS DATA IN VACON[®] 20 APPLICATION ACCN1004

Process data is an address area for fieldbus control. Fieldbus control is active when the value of parameter 2.1 (Control place) is 1 (= fieldbus). The content of the process data can be programmed in the application. The following tables present the process data contents in VACON[®] 20 Application. Please refer to VACON[®] 20 Complete Manual for details.

Table 8. Output process data

ID	Modbus register	Name	Scale	Type
2101	32101, 42101	FB Status Word	-	Binary coded
2102	32102, 42102	FB General Status Word	-	Binary coded
2103	32103, 42103	Actual speed	0.01	%
2104	32104, 42104	Programmable by P10.1 (Default: Frequency reference)	-	-
2105	32105, 42105	Programmable by P10.2 (Default: Output frequency)	0.01	+/- Hz
2106	32106, 42106	Programmable by P10.3 (Default: Motor speed)	1	+/- Rpm
2107	32107, 42107	Programmable by P10.4 (Default: Motor voltage)	0.1	V
2108	32108, 42108	Programmable by P10.5 (Default: Motor torque)	0.1	+/- % (of nominal)
2109	32109, 42109	Programmable by P10.6 (Default: Motor current)	0.01	A
2110	32110, 42110	Programmable by P10.7 (Default: Motor power)	0.1	+/- % (of nominal)
2111	32111, 42111	Programmable by P10.8 (Default: DC link voltage)	1	V

Table 9. Input process data

ID	Modbus register	Name	Scale	Type
2001	32001, 42001	FB Control Word		Binary coded
2002	32002, 42002	FB General Control Word		Binary coded
2003	32003, 42003	Actual speed	0.01	%
2004	32004, 42004	Programmable by P10.9		
2005	32005, 42005	Programmable by P10.9		
2006	32006, 42006	Programmable by P10.9		
2007	32007, 42007	Programmable by P10.9		
2008	32008, 42008	Programmable by P10.9		
2009	32009, 42009	-	-	-
2010	32010, 42010	-	-	-
2011	32011, 42011	-	-	-

NOTE! 2004 - 2007 can set as PID Control Reference by setting P15.1(Setpoint selection) or PID Actual value by setting P15.4 (Feedback value selection)!

2004 - 2007 can be set as the Analogue Output by P9.1, P9.5, P9.9.

2004 - 2008 can set as Aux Control Word with P10.9:

b0: Run enable

b1: acc / dec ramp 2 selection

b2: freq reference 2 selection

NOTE!

- AUX CW is active when configured, even if control place is not the fieldbus
- b0 Run enable is computed in AND with a possible Run enable signal from digital input. Fall of enable will cause coasting stop.

Status word (output process data)

Information about the status of the device and messages is indicated in the Status word. The Status word is composed of 16 bits the meanings of which are described in the table below:

Table 10. Status word (output process data)

Bit	Description	
	Value = 0	Value = 1
B0, RDY	Drive not ready	Drive ready
B1, RUN	Stop	Run
B2, DIR	Clockwise	Counter-clockwise
B3, FLT	No fault	Fault active
B4, W	No alarm	Alarm active
B5, AREF	Ramping	Speed reference reached
B6, Z	-	Drive is running at zero speed
B7 - B15	-	-

General status word (output process data)

Information about the status of the device and messages is indicated in the General status word. The General status word is composed of 16 bits the meanings of which are described in the table below:

Table 11. General status word (output process data)

Bit	Description			
	Value = 0	Value = 1		
B0, RDY	Drive not ready	Drive ready		
B1, RUN	Stop	Run		
B2, DIR	Clockwise	Counter-clockwise		
B3, FLT	No fault	Fault active		
B4, W	No alarm	Alarm active		
B5, AREF	Ramping	Speed reference reached		
B6, Z	-	Drive is running at zero speed		
B7, F	-	Fieldbus control active		
B8 - B12	-	-		
Bit	Control Place			
	I/O	PC tool	Keypad	Fieldbus
B13	1	0	0	0
B14	0	1	1	0
B15	0	1	0	1

Actual speed (output process data)

This is actual speed of the AC drive. The scaling is -10000...10000. The value is scaled in percentage of the frequency area between set minimum and maximum frequency.

Control word (input process data)

The three first bits of the control word are used to control the AC drive. By using control word it is possible to control the operation of the drive. The meanings of the bits of control word are explained in the table below:

Table 12. Control word (input process data)

Bit	Description	
	Value = 0	Value = 1
B0, RUN	Stop	Run
B1, DIR	Clockwise	Counter-clockwise
B2, RST	Rising edge of this bit will reset active fault	
B5	Not used	

Speed reference (input process data)

This is the Reference 1 to the AC drive. Used normally as Speed reference. The allowed scaling is 0...10000. The value is scaled in percentage of the frequency area between the set minimum and maximum frequencies.

6.3.2 MODBUS PROCESS DATA IN VACON[®] 20X AND VACON[®] CP APPLICATION ACIT1075

Process data is an address area for fieldbus control. Fieldbus control is active when the value of parameter 1.11 (Control place) is 2 (= fieldbus). The content of the process data can be programmed in the application. The following tables present the process data contents in VACON[®] ACIT1075 Application. Please refer to VACON[®] 20 CP X Multipurpose Application Manual for details.

6.3.2.1 Fieldbus Data IN: Master -> Slave

Table 13.

Modbus register	Name	Description	Range
2001	Control word	Drive control	Binary coded: b0: Run b1: Reverse b2: Fault Reset(on edge) b8: forces control place to fieldbus b9: forces reference source to fieldbus
2002	General control word	Not used	
2003	Speed reference	Reference	0...10000 as 0,00...100,00% of Min freq. - Max freq. range
2004	Fieldbus Data IN 1	Programmable	0...10000
2005	Fieldbus Data IN 2	Programmable	0...10000
2006	Fieldbus Data IN 3	Programmable	0...10000
2007	Fieldbus Data IN 4	Programmable	0...10000
2008	Fieldbus Data IN 5	Programmable	0...10000
2009	Fieldbus Data IN 6	Not used	-
2010	Fieldbus Data IN 7	Not used	-
2011	Fieldbus Data IN 8	Not used	-

NOTE!

- CW b0 Run is acquired on edge, only if the drive is in Ready state (see Status Word b0) and actual control place is Fieldbus.
- CW b2 Fault Reset is active even if control place is not the Fieldbus.

Fieldbus data input mapping

Fieldbus Data inputs from 1 to 5 can be configured, with parameters P11.9 - P11.12, as:

Table 14.

Process Data IN	Description	Note
Aux Control Word	b0: enable b1: acc/dec ramp 2 selection b2: freq reference 2 selection b3: digital output 1 control b4: digital output 2 control	<ul style="list-style-type: none"> • b0 Enable is considered only when control place is the Fieldbus. It is computed in AND with a possible enable from digital input. Fall of enable will cause coasting stop. • b2 FreqRef2 Sel is considered only when control place is the Fieldbus. • functions related to bit1, b3 and b4 are available also when control place is not the Fieldbus. Aux CW must anyway be mapped onto a PDI, by means of parameter P11.9.
PID Setpoint	active if P12.1 = 3, range 0 - 10000 as 0 - 100.00% of regulation.	
PID Actual value	active if P12.4 = 2, range 0 - 10000 as 0 - 100.00% of regulation.	
Analogue Out Cntrl	active if P5.1 = 8, range 0 - 10000 as 0 - 100.00% of output.	

6.3.2.2 Fieldbus Data OUT: Slave -> Master

Table 15.

Modbus Register	Name	Description	Range
2101	Status word	Drive state	Binary coded: b0: Ready b1: Run b2: Reverse b3: Fault b4: Warning b5: Freq. reference reached b6: Zero speed
2102	General Status word	Drive state	As Status word and: b7: Control place is fieldbus
2103	Actual speed	Actual speed	0...10000 as 0.00...100.00% of Min freq. - Max freq. range
2104	Fieldbus Data OUT 1	Programmable	See P11.1
2105	Fieldbus Data OUT 2	Programmable	See P11.2
2106	Fieldbus Data OUT 3	Programmable	See P11.3
2107	Fieldbus Data OUT 4	Programmable	See P11.4
2108	Fieldbus Data OUT 5	Programmable	See P11.5
2109	Fieldbus Data OUT 6	Programmable	See P11.6
2110	Fieldbus Data OUT 7	Programmable	See P11.7
2111	Fieldbus Data OUT 8	Programmable	See P11.8

6.4 EXAMPLE MESSAGES

6.4.1 EXAMPLE 1 - WRITE PROCESS DATA

Write the process data 42001...42003 with command 16 (Preset Multiple Registers).

Command Master - Slave:

Table 16.

ADDRESS		01 hex	Slave address 1 hex (= 1)
FUNCTION		10 hex	Function 10 hex (= 16)
DATA	Starting address HI	07 hex	Starting address 07D0 hex (= 2000)
	Starting address LO	D0 hex	
	No. of registers HI	00 hex	Number of registers 0003 hex (= 3)
	No. of registers LO	03 hex	
	Byte count	06 hex	Byte count 06 hex (= 6)
	Data HI	00 hex	Data 1 = 0001 hex (= 1). Setting control word run bit to 1.
	Data LO	01 hex	
	Data HI	00 hex	Data 2 = 0000 hex (= 0).
	Data LO	00 hex	
	Data HI	13 hex	Data 3 = 1388 hex (= 5000), Speed Reference to 50.00%
Data LO	88 hex		
ERROR CHECK	CRC HI	C8 hex	CRC field C8CB hex (= 51403)
	CRC LO	CB hex	

Message frame:

Table 17.

01	10	07	D0	00	03	06	00	01	00	00	13	88	C8	CB
----	----	----	----	----	----	----	----	----	----	----	----	----	----	----

The reply to Preset Multiple Registers message is the echo of 6 first bytes.

Answer Slave - Master:

Table 18.

ADDRESS		01 hex	Slave address 1 hex (= 1)
FUNCTION		10 hex	Function 10 hex (= 16)
DATA	Starting address HI	07 hex	Starting address 07D0 hex (= 2000)
	Starting address LO	D0 hex	
	No. of registers HI	00 hex	Number of registers 0003 hex (= 3)
	No. of registers LO	03 hex	
ERROR CHECK	CRC HI	80 hex	CRC 8085 hex (= 32901)
	CRC LO	85 hex	

Reply frame:*Table 19.*

01	10	07	D0	00	03	80	85
----	----	----	----	----	----	----	----

6.4.2 EXAMPLE 2 - READ PROCESS DATA

Read the Process Data 42103...42104 with command 4 (Read Input Registers): for this example when using ACCN1004 set P10.1=1, when using ACIT1075 set P11.1=0.

Command Master - Slave:*Table 20.*

ADDRESS		01 hex	Slave address 1 hex (= 1)
FUNCTION		04 hex	Function 4 hex (= 4)
DATA	Starting address HI	08 hex	Starting address 0836 hex (= 2102)
	Starting address LO	36 hex	
	No. of registers HI	00 hex	Number of registers 0002 hex (= 2)
	No. of registers LO	02 hex	
ERROR CHECK	CRC HI	93 hex	CRC field 93A5 hex (= 37797)
	CRC LO	A5 hex	

Message frame:*Table 21.*

01	04	08	36	00	02	93	A5
----	----	----	----	----	----	----	----

The reply to the Read Input Registers message contains the values of the read registers.

Answer Slave - Master:*Table 22.*

ADDRESS		01 hex	Slave address 1 hex (= 1)
FUNCTION		04 hex	Function 4 hex (= 4)
DATA	Byte count	04 hex	Byte count 4 hex (= 4)
	Data HI	13 hex	Actual Speed = 1388 hex (=5000 => 50.00%)
	Data LO	88 hex	
	Data HI	09 hex	Output Frequency = 09C4 hex (=2500 =>25.00Hz)
	Data LO	C4 hex	
ERROR CHECK	CRC HI	78 hex	CRC field 78E9 hex (=30953)
	CRC LO	E9 hex	

Reply frame:*Table 23.*

01	04	04	13	88	09	C4	78	E9
----	----	----	----	----	----	----	----	----

7. FAULT TRACING

When an unusual operating condition is detected by the AC drive control diagnostics, the drive initiates a notification visible, for example, on the keypad. The keypad will show the ordinal number of the fault, the fault code.

The fault can be reset with the Reset button on the control keypad or via the I/O terminal. The faults are stored in the Fault history menu which can be browsed. The different fault codes you will find in the table below. This fault table presents only the faults related to the fieldbus in use.

NOTE! When contacting distributor or factory because of a fault condition, always write down all texts and codes on the keypad display and send a description of the problem together with the *Drive Info File* to your local support.

7.1 TYPICAL FAULT CONDITIONS

Table 24. Typical fault conditions

Fault condition	Possible cause	Remedy
Termination resistor	Missing or excessive termination resistor.	Install termination resistors at both ends of the fieldbus line.
Cabling	<ul style="list-style-type: none"> Supply or motor cables are located too close to the fieldbus cable Wrong type of fieldbus cable Too long cabling 	
Grounding	Inadequate grounding.	Ensure grounding in all points on the net
Connections	Faulty connections. <ul style="list-style-type: none"> Excessive stripping of cables Conductors in wrong terminals Too loose connections of conductors 	
Parameter	<ul style="list-style-type: none"> Faulty address Overlapping slave addresses Wrong baud rate Wrong control place selected 	

7.2 RS-485 BUS BIASING

When none of the devices on the RS-485 bus is sending data, all devices are in idle status. This being the case, the bus voltage is in indefinite state, usually near 0 V due to the termination resistors. This may cause problems in character reception because the single characters in serial communication begin with start bit referring to bus status '0' with voltage of less than -200mV whereas the bus status '1' corresponds to bus voltage of more than +200mV. The RS-485 standard considers the voltage interval -200mV...+200mV as undefined state. Bus biasing is therefore needed to maintain the voltage in status '1' (above +200mV) also between the messages.

By activating the line termination using the dedicated dip switch described in Chapter 4.1.1, also a 560 Ohm resistor for line polarization is activated.

7.3 OTHER FAULT CONDITIONS

The following fault tracing diagram will help you to locate and fix some of the most usual problems. If the problem persists contact your local distributor.

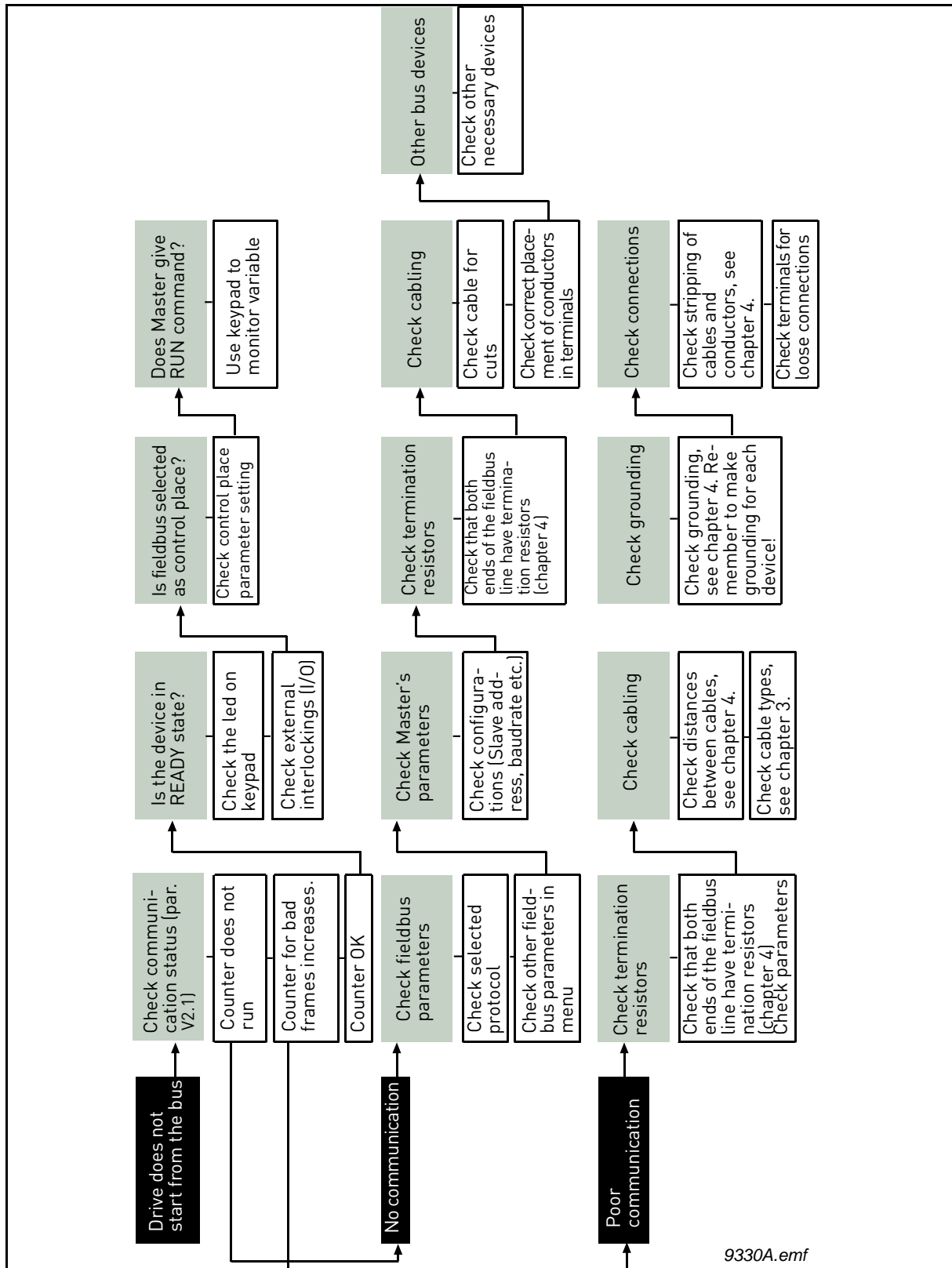

Figure 3. Fault tracing diagram for Modbus RTU

8. QUICK SETUP

Following these instructions, you can easily and fast set up your Modbus for use:

1	<p>Choose control place.</p> <p>A. Press LOC/REM button on keypad to select <i>Remote Control Place</i></p> <p>B. Select <i>Fieldbus</i> as remote control place. The parameter depends on the application used:</p> <ul style="list-style-type: none"> • P2.1 in VACON[®] 20 • P1.11 in VACON[®] 20 X and VACON[®] 20 CP
2	<p>Make these settings in the master software</p> <p>A. Set Control Word to '0' by writing the data 0000h to the register 2001_d.</p> <p>B. Set Control Word to '1' by writing the data 0001h to the register 2001_d.</p> <p>C. AC drive status is RUN</p> <p>D. Set Speed Reference value to '5000' (=50.00%) by writing the data 1388h to the register 2003_d.</p> <p>E. <i>Actual speed</i> is 5000 (25.00 Hz if MinFreq is 0.00 Hz and MaxFreq is 50.00 Hz)</p> <p>F. Set Control Word to '0' by writing the data 0000h to the register 2001_d.</p> <p>G. AC drive status is STOP.</p>

9. APPENDIX 1 - PROCESS DATA

Process Data IN (Master to Slave)

Use of Process Data In variables depends on the used application. The configuration of the data is free.

Process Data OUT (Slave to Master)

Use of Process Data Out variables depends on the used application.

The Fieldbus Master can read the AC drive's actual values using process data variables.

VACON[®]

www.danfoss.com

Vacon Ltd
Member of the Danfoss Group
Runsorintie 7
65380 Vaasa
Finland

Document ID:



DPD01925A

Rev. A

Sales code: DOC-INSV20MODBUS+DLUK